

---

**ABSTRACT**

Electric vehicles are the future of the modern day transit system. Their increasing penetration on the road over the conventional IC engines is producing a great challenge to the distribution system operators. As the charging system of Electric Vehicles (EV's) represent a new high power consumption load. To increase the ranges of distance which could be covered by an EV, the manufactures are increasing the size of the batteries on these vehicles. To meet the demand of EV load public DC Fast-Charging Stations (DCFCS) are being established rapidly. This paper discusses the alternative solution within the DCFCS by introducing Battery Energy Storage method to decrease the operational cost of charging station while also mitigating the impacts on power grid during peak load periods. A proper design of the DCFCS which can effectively decouple the peak load demand on the main grid caused by the EVs and also decreasing the connection fee on the station. The various economical and technical issues, such as installation cost, connection fee and life cycle cost of the batteries are also discussed in this paper.

**Keywords:** Battery energy storage, cost-benefit analysis, fast-charging station, electric vehicles, market design

---

**I. INTRODUCTION**

The greenhouse gas emissions and limited fossil fuel resources, as well as the constant rise in oil prices, have expanded the debates to replace gasoline-fuel with electric vehicles (EVs). To reduce the CO<sub>2</sub> emissions, European cities are increasing driving restrictions on gasoline vehicles around the metropolitan areas, and a smart alternative could be the introduction of EVs [1]. Thanks of driving limitation from gasoline vehicles in urban areas the EV market has started to grow, and many European countries are contributing with incentives to buy hybrid and fully electric vehicles [2]-[3].

The widespread use of EVs requires investigating the impacts of vehicles' charging systems on the electrical grids. The EV charging infrastructures need smart management systems able to support their required energy demand. The EN /IEC 61815 and automotive engineers in U.S. SAE J1772 have proposed their standards with charging modes for EVs and the maximum current delivered both on alternating and direct current (AC and DC) [4]-[5]. Charging modes are classified according to international standards as mode 1, 2, 3 and 4 for the EV inductive charging system. The 61851 applies to on- board and off-board equipment for charging EVs. According to the International Standard Classification for EV chargers, Mode 1,2 and 3 are designed to charge EVs in AC and mode 4 in DC. The power delivered in AC is between 7 kW and 43kW. The charging rate requires about 2-3 hours to store the energy needed to cover 110km. The DC method is designed for recharging in a short period. The DC charging facilities are installed at high power levels. Currently, the delivered power in DC is between 50 kW and 150 kW for public charging stations with a charging rate about 45 min and 30 min to store energy for 110km of driving [5]. The fast- charging station has met implementation difficulties in the major European cities because of charging rate restrictions on the EV batteries [6]. With the new technologies available on the market and especially the evolution of power electronics, interfaces, as well as battery energy storage, will be playing an important role for developing competitive EVs. Recently, EV auto motives are investing on new EV Lithium batteries, which are able to accept high rate power between 150kW and 300kW in DC.

[IDSTM-18]

ICTM Value: 3.00

The main issues of the DC fast charging station is to manage the congestion during the peak hours and the high-cost connection on the distribution grid [7]. To address these issues, research is moving in different directions. In [8] a coordinated charging system is proposed to minimize the power and maximize the main grid load force to approach an optimal charging profile for EVs. To avoid the congestion from EVs, a dynamic price for the users to keep the reliability of the electrical grid is proposed in [9]. Only a few researchers are working to determine the fast charging stations' demand and their impact on the electrical grids, even though the DCFCS has a strong impact especially during the peak demand. Consequently, it is important to design an appropriate fast-charging station for EVs, which is able to meet the expected demand.

Designing an appropriate DC-charging station in low voltage (LV) is important to avoid the connection in MV and minimize the operating costs [10]-[11]. In addition, distribution system operators (DSOs) are focused on minimizing losses and reducing the size of the electrical lines to mitigate the network congestion [12]-[13]. DCFCS station can significantly increase during the peak-load demand and high connection fees to the grid operators as well as the cost of the larger transformers/cables in MV grids.

Recent studies have focused on using battery energy storage (BES) as a buffer between the grid and the charging stations to reduce their peak consumption, but more work is required on the optimal size of battery BES within the charging stations [14]. An important aspect to take into account is the reduction of the cost of the lithium-ion battery; this could be transformed into an intelligent opportunity for integrating the penetration of EVs and DC fast charging stations with Li-ion batteries support. The cost of the Li-ion battery for electric vehicle (BEV) represents the 25% of the total cost of the EV. The annual cost reduction of BEVs has been estimated around 8% [15]-[17].

The study aims to determine an optimal design of the DC fast -charging station with the integration of BESs to reduce its grid impact, with a cost-benefit analysis (CBA) of: the cost of the installation, lifetime of the batteries and price of the electricity. The operation of our DCFCS is based on exchanges of the BESs that allow one of the batteries (BES2) to be charged from the grid while the other (BES1) is charging an electric vehicle. The user that immediately followed would be served by BES2 that has just been charged. This method has the advantage of reducing the grid Utility demand. A cost-benefit analysis has been analyzed to evaluate the effectiveness and applicability of the chargers in large scale.

## II. METHODOLOGY

This section presents the methodology applied for a CBA by using BESs within the charging stations through the comparison without batteries. The first method uses the BESs within the charging stations with the connection to LV grids and the second method the charging stations will be connected to the medium voltage (MV) grid. In the context of the technological evolution of batteries and decreasing costs [15]-[17], the main objective pursued by the CBA hereby proposed is to determine the costs of the infrastructures and lifetime of different storage that make the installation of batteries profitable. In particular, if it is convenient for the Electric Vehicle Supply Equipment Operator (EVSEO) the integration of batteries within the DC chartering stations. The EVSEO could be the DSO or a private company such as car sharing. The economic analysis of investments is a critical step especially if we do not have a clear perspective of the EV market penetration. The main elements of investment are: the

capital cost or initial investment, the interest rate, the return on the investment and the lifetime of the investment. Several methods can be used, according to the company's internal evaluation criteria for investment. In function of the importance of the investment, sophisticated methods can be used. In this case study two methods has been used

### A. The Method 1

*The Method 1* does not consider the time value of the money over the years and interests.

#### *The payback period*

The payback period (PBP) is the time required to recover the capital investment from the net cash flow and thus shorter payback periods would make a BES project more attractive to investors. The PBP is calculated as:

$$\text{Payback period} \square \frac{\text{Cost of investment}}{\text{Annual revenues}}$$

The two terms of the PBP ratio can be either before or after taxes depending on the requirements of the investor. The PBP method does not consider the time value of the money during the years, it takes the interest as a unknown factor. Nevertheless, the payback method is very simple, and it can serve as a yardstick to compare possible investments.

### Internal Rate of Return

The internal rate of return (IRR) is the reciprocal of the PBP and it is generally expressed as a percentage.

$$\text{Internal Rate of Return} = \frac{\text{Annual revenues}}{\text{Cost of investment}}$$

The IRR is the discount rate at which the net present value of all cash flows is equal to zero. The projects with the highest percentage of IRR would be considered the most attractive investment among projects with similar characteristics. The IRR method does not consider the time value of the money over the years; it takes the interest as a unknown factor.

### The method 2

The Method 2 considers the time value of the money over the years and interests. Methods using life-cycle costing are based on the conversion of investment and annual cash flow at various times to their equivalent present values and vice versa. It takes the interest as a known factor. Several factors are used to accomplish these conversions:

Future worth factor (FWF) converts a single present amount (at year zero) to an amount at a future point in time:

$$\text{Future worth factor} = (1+r)^n$$

Present worth factor (PWF) which is used in this paper converts a future amount to an amount today (at the year zero):

$$\text{Present worth factor} = \frac{1}{(1+r)^n}$$

$$\text{Present annuity factor} = \sum_{t=1}^n \frac{1}{(1+r)^t}$$

Respectively,  $r$  is the discount rate (interest), and  $t$  is the number of time periods or years in this case.

## III. CASE STUDY

In this paper, two different layouts have been analyzed to connect the DCFCS. With a CBA we are able to compare two typologies of DCFCSs within the electrical grid. The first layout will consider a CBA of the DCFCSs in LV grids with the installation of lithium of batteries. In this case the benefits assessed include the reduction of grid costs in terms of reinforcement such as new transformer and new lines as well as the fee connection in MV. The second layout considers a CBA - to justify a standard investment of the charging stations in MV grids with a new transformer and new lines. For each of them, a scenario with a business model situation has been done and the EV load demand in both methods is considered equivalent. The four charging modes according to IEC 61851 are applied for the EV conductive charging on the on-board and off-board charging systems.

The most used system at the moment is charging EVs in AC with an on-board charger. Another approach is to use an off-board charger for delivering direct current (DC), for charging in a short period. Special charging spots are operating at high power levels by using medium voltage (MV). The EV charging modes are the following: Charging Mode 1: home in AC 11kW with maximum 16A, ; Charging Mode 2: private facilities 22kW with maximum 32A, ; Charging Mode 3: public charging stations AC 43kW with maximum 63A, ; and Charging Mode 4: public charging stations DC 240-300kW with maximum 400A [3]-[4]. The mode 4 has been implemented for the AC/DC charging by the use of off-board chargers. Typically, the charging time of the mode 4 is from 50 to 30 minutes to reach 80% of battery SoC with a power between 50 and 120kW. The charging systems used now are mode 2 and mode 3, for the following reasons: international standards availability, low infrastructure costs, availability of the power grid. The charging architecture in AC is robust, but it has power limitations of 43kW and high conversion losses on the EV side. In mode 3 the charging rate

to reach 80% of the EV battery with 22kW takes approximately 1 hour with an EV of 20kWh. To solve the problem of the low range, the major car manufacturers are increasing the battery pack of the new models from 20/25kWh to 40/60kWh such as Tesla model 3 and eGolf. Therefore, charging in AC will represent an issue for the long charging time and in particular space congestion of the public parking as well as congestion on the electrical grids. Recently, some company are starting to develop new fast charging systems in DC because the standard allows charging with 400A and maximum power of 240kW -300kW in Combined Charging System (Combo) State of the art at the moment is the following: Tesla 120kW, connected in MV (outside the cities), 50kW by ABB with combo in LV (inside the cities), 62.5kW by Chademo system in LV (inside the cities). From 2018 ABB has designed a charger of 150kW in combo in MV (inside and outside the cities). The DC charger significantly reduces the charging time and the conversion losses on the EV side

#### A. Connection to LV grids of the DCFCD with BES – case A

To avoid the connection to MV especially within residential areas, the DCFCS in combination with the BES can represent a smart solution. Thanks to the large scale production of power electronics and batteries the cost of the EV-battery is decreasing every year around 8 % [15]-[17]. This represents a chance to evaluate possible scenarios of the DCFCS in order to develop a new charging stations and control methods for these flexible loads [13]. In addition, DCFCS with the BESs gives the opportunity to the users to recharge the EVs up to 80% of their SoC with charging rate of around 10 minutes. The new design of the charging stations is based on the installation of two identical battery energy system (BES1 and BES2) that physically decouples a DC fast charging station (DCFCS) from an LV distribution grid, as shown in Figure 1. The operation of such a system is based on successive switches of the BES connections that allow one of the batteries (BES2) to be charged from the grid while the other (BES1) is charging an EV and vice versa [10]- [11].

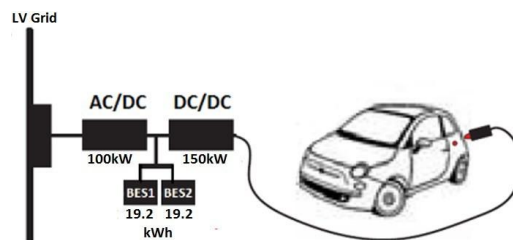

Figure 1. DC fast charging station in mode 4 with BESs

The case study uses an AC/DC converter of 100kW and charging rate of 6C (9.7min) [11]. The discharging rate through the DC/DC is 9C (6.7min) with a converter of 150kW. To satisfy the energy demand from EVs, the optimal BES for a DCFCS is 16kWh because it meets the highest level of SoCs satisfaction. It means more than 80% of the commercial EV can be charged up to their 80% of SoC [11]. Each BES has been oversized of 19.2 kWh because it cannot exceeding 20% SoC for two reasons: overheating issues and faster degradation of the battery. The configuration of the case A of the DCFCS with BESs is as shown in Figure 2:

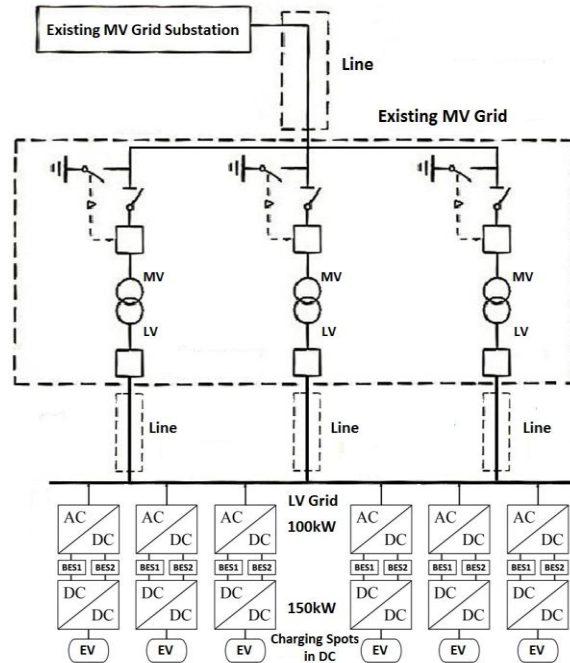
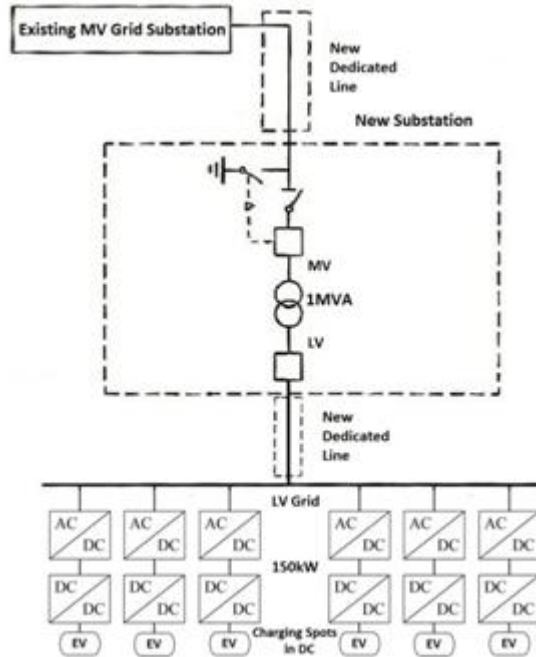

Figure 2. DC fast charging station in mode 4 with BESSs connected to LV

This case study takes into account the maximum power of the LV grids in order to prevent the connection in MV. To avoid the connection to MV and in particular the high costs for the grid reinforcement in many cases DSO's load should not exceed 500kW-600kW [20]-[21]. In this study case, six chargers of 100kW each can prevent the connection to MV and thanks to the DC/DC converters; the chargers provide 150kW on the EV side through the discharging rate of 9C of BESSs. The disadvantage of this system is the costs of the batteries and the replacement at the end of their useful life. The CBA of the case A will consider costs of the DC charging stations, battery replacement as well as installation costs. The case A takes into account different Lithium batteries with different cycles. The energy sold to the final users in the CBA is considered as revenue in function of the EVs daily recharged. The details of the cost-benefit analysis steps will be discussed in the following section through the use of different scenarios.

**A. Connection to MV grids of the DCFCD – case B**

The case B is a classic connection to MV when the electrical load exceeds 600kW. The choice of the DCFCS has been done according to the case A with the same EVs load demand and charging time. Accordingly, six DC charging stations of 150kW require the connection to MV because the electrical load is 900kW. The case B has high investment costs in terms of grid reinforcement, and it requires new dedicated lines for the connection to MV and a new substation with a transformer of 1MVA. This grid connection also has space



restrictions, especially if the installation takes place in the cities. The infrastructure costs include: distribution network expansion, new lines and the costs of the DC charging stations as well as the installation costs. The energy sold to the final users is considered as revenue in function of the EVs daily recharged. Many simplifications have been assumed to compare the two CBAs such as the EVs load demand. The details of the cost-benefit analysis steps will be discussed in the following section through the use of different EV scenarios.

**IV. FINANCIAL ASSESSMENT AND COST-BENEFIT ANALYSIS RESULTS**

The methodology and inputs used in section III are used to perform the cost-benefit analysis, and the financial assessment of the case A and case B. The results of this work and comparison of the systems are presented in this section.

**A. Cost and Revenue calculation with BES – case A**

The annual costs and benefits associated to the case A – BES within the charging stations are calculated taking into account the infrastructure costs and as benefits the consumption of electricity. The total cost per year is:

$$Total\ annual\ cost = C_s + I_n + R_e + O\&M \quad (8)$$

where  $C_s$  are the component costs (including the chargers and batteries),  $I_n$  is the installation cost,  $R_e$  is the cost of replacing the batteries in function of the EVs demand, and  $O\&M$  is the operation and maintenance cost. The total revenue per year can be calculated as:

$$Total\ annual\ revenue = (E \cdot P) \cdot T \quad (9)$$

where  $E$  is the daily energy consumed in function of the EV demand,  $P$  is the price paid by the EV users and  $T$  is the total time in a year measured in days.

**B. Cost and Revenue calculation with connection to MV grids – case B**

The annual costs and benefits associated with the case B - classic connection in MV are represented by comparing similar investments [20]. This configuration takes into account the infrastructure costs, new lines and a transformer of 1MVA as well as the DC charging stations and the installation costs. The benefits are the consumption of electricity. The total cost per year is:

$$Total\ annual\ cost = C_s + I_n + O\&M \quad (10)$$

[IDSTM-18]

ICTM Value: 3.00

where  $C_s$  are the component costs (including the chargers, lines and transformer). The total revenue per year can be calculated as:

$$\text{Total annual revenue} = (E \cdot P) \cdot T \quad (11)$$

### C. Financial, Market and Technology Inputs

The most important inputs used in this financial assessment are summarized in Figure 4, Figure 5, Table I and Table II. The financial performance of the case A and case B are compared assuming the rating and costs listed:

- Discount rate ( $r$ ): 4% [18]
- Li-ion battery price forecast: 200€/kWh [15]-[17] (2020)
- Component costs: 1km line in LV and 1km in MV and transformer of 1MVA [22]
- EV demand: 16kWh [11]
- DCFCS cost: 50,000€
- The investment life is 20 years

Figure 4 and 5 compare the financial performance of five case studies by using payback period and benefit-cost ratio with an interest rate of 4%. In Figure 4 and 5 the red lines show financial performance by using the case B connection to MV grid. Instead, in the case A the blue line and orange line are representing the current technology of lithium ion battery with 5000 and 10000 cycles with energy density of 160Wh/kg. The green line and violet line are representing future generation of the lithium battery with 25000 or 30000 cycles, such as Lithium Titanate (LTO), which has half energy density (80Wh/kg) but high performance in terms of cycles, or Lithium-Sulfur (370Wh/kg) or Lithium-Air Battery (1700Wh/kg) [23]. The cycles are strongly related to the battery replacement. As expected, increasing the number of battery replacements has a significant impact on the financial performance of the battery storage project (line blue and orange). Batteries with high cycles will be competitive to the case B standard configuration as shown Table I and II. Figure 5 shows that the benefit-cost ratio B/C ratio - case A is higher than case B as long as the EV demand does not exceed 325 EVs/day.

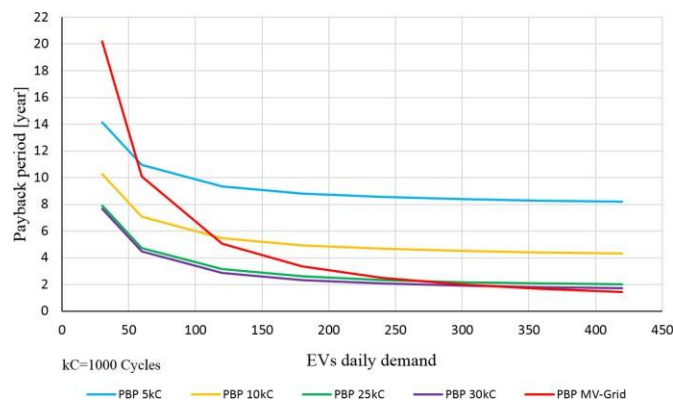

Figure 4. Payback period (5) versus EVs daily demand

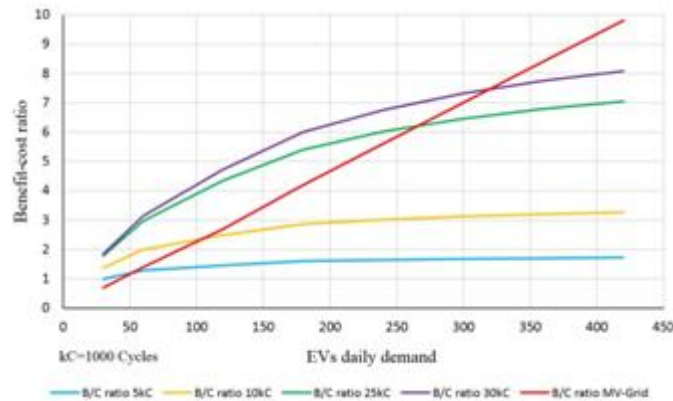

Figure 5. Benefit-cost ratio (7) versus EVs daily demand

TABLE I

COST - REVENUE CALCULATION WITH BES 30000 CYCLES – CASE A

| EVs daily demand | Investment cost [€] | Payback [years] | IRR [%] | NPV [€] | B/C ratio |
|------------------|---------------------|-----------------|---------|---------|-----------|
| 30               | -452273             | 7.67            | 12.2%   | 349034  | 1.84      |
| 60               | -528468             | 4.48            | 22.8%   | 1074145 | 3.15      |
| 120              | -680857             | 2.89            | 35.9%   | 2524370 | 4.73      |
| 180              | -833231             | 2.36            | 44.1%   | 3974608 | 6.00      |
| 240              | -985620             | 2.09            | 49.8%   | 5424833 | 6.76      |
| 300              | -1138008            | 1.93            | 53.9%   | 6875057 | 7.32      |
| 360              | -1290396            | 1.82            | 54.8%   | 8325282 | 7.75      |
| 420              | -1442785            | 1.75            | 57.2%   | 9775507 | 8.09      |

TABLE II

COST - REVENUE CALCULATION CONNECTION TO MV GRIDS CASE B

| EVs daily demand | Investment cost [€] | Payback [years] | IRR [%] | NPV [€]  | B/C ratio |
|------------------|---------------------|-----------------|---------|----------|-----------|
| 30               | -1190000            | 20.18           | -0.1%   | -388693  | 0.70      |
| 60               | -1190000            | 10.09           | 7.6%    | 412613   | 1.40      |
| 120              | -1190000            | 5.05            | 19.2%   | 2015226  | 2.71      |
| 180              | -1190000            | 3.36            | 29.6%   | 3617839  | 4.20      |
| 240              | -1190000            | 2.52            | 39.6%   | 5220452  | 5.60      |
| 300              | -1190000            | 2.02            | 49.5%   | 6823065  | 7.00      |
| 360              | -1190000            | 1.68            | 59.5%   | 8425679  | 8.40      |
| 420              | -1190000            | 1.44            | 69.4%   | 10028292 | 9.80      |

## V. CONCLUSIONS

A financial assessment of the BES within the DC- fast charging has been performed. The payback period, internal rate of return, net present value and benefit-cost ratio were determined to evaluate the financial performance of the five case studies. The financial performance of the case A- BES within the DFCs is crucially dependent on the life cycle cost of the batteries; on the contrary, the case B -MV connection is closely linked to the EV demand. The results of the case A have shown that the number of battery replacements affects the main economic parameters significantly on the financial performance. The finding of the financial assessment suggests the following: Case A: using batteries with low cycles such as 5000 or 10000 is not economically viable because the investment has constant battery replacement costs. Instead, batteries with big cycles 25000-30000 have the benefit-cost ratio higher than the Case B as long as the EVs daily demand is between 10 and 325. The case B has illustrated that the profitability of the investment increases if and only if the EVs demand penetration is bigger than 325 EVs/day. To conclude, the work presented in this paper can help to



understand the business case behind the use of different storage systems within the DCFCSs. In the future, a drastic reduction of the battery costs of different technologies could represent a profitable alternative for the considered cases.

## VI. REFERENCES

- [1] European commission “mobility and transport” [www.ec.europa.eu/transport/home\\_en](http://www.ec.europa.eu/transport/home_en).
- [2] Nordhavn project; Design - dimensioning of the energy infrastructure of future sustainable cities, <http://www.energylabnordhavn.dk/>
- [3] Green eMotion project – preparing the future of European electromobility \_ <http://www.greenemotion-project.eu/>
- [4] IEC 62196: Connectors for conductive charging of electric vehicles.
- [5] IEC 61851: Conductive charging system / DC EV charging station.
- [6] Remus Teodorescu, “Storage Systems based on Li-ion Battery for Grid Support and Automotive Application”: Book, Aalborg University
- [7] Wen Chen and Chunlin Guo, “The Impact of fast charging for EVs on Distribution System”, ISSN: 1662-8985, vols. 1070, pp 1664-1667
- [8] K. Clement, E. Haesen, and J. Driesen, “Coordinated charging of multiple plug-in hybrid electric vehicles in residential distribution grids,” in Proc. IEEE PES Power Syst. Conf. Expo, Mar. 2009, pp. 1–7.
- [9] S. Martinenas, A. B. Pedersen, M. Marinelli, P. B. Andersen, C. Træholt, “Electric Vehicle Smart Charging using Dynamic Price Signal” IEVC, 2014 IEEE International, pp.1-5, Florence, 17 Dec. 2014.
- [10] M.Gjelaj, C. Træholt, S. Hashemi, P. B. Andersen “DC Fast-Charging Stations for EVs Controlled by a Local Battery Storage in Low Voltage Grids” unpublished, presented at the 12th IEEE PES PowerTech Int. Conf., Manchester, United Kingdom, 2017
- [11] M.Gjelaj, C. Træholt, S. Hashemi, P. B. Andersen “Optimal Design of DC Fast-Charging Stations for EVs in Low Voltage Grids” unpublished, presented at the ITEC2017 IEEE PES Int. Conf., Chicago, United States, 2017
- [12] L. P. Fernández, T. G. S. Román, R. Cossent, C. M. Domingo, and P. Frías, “Assessment of the impact of plug-in electric vehicles on distribution networks,” IEEE Trans. Power Syst., vol. 26, no. 1, pp. 206–213, Feb. 2011.
- [13] J. Hu, S. You, M. Lind, and J. Østergaard, “Coordinated charging of electric vehicles for congestion prevention in the distribution grid,” Smart Grid, IEEE Transactions on, vol. 5, no. 2, pp. 703, March 2014
- [14] Sanzhong Bai and Srdjan M. Lukic, “Unified Active Filter and Energy Storage System for an MW Electric Vehicle Charging Station”, ” IEEE International, pp, vol. 28, no. 12, December 2013
- [15] Björn Nykvist1 and Måns Nilsson, “Rapidly falling costs of battery packs for electric vehicles” , DOI: 10.1038/NCLIMATE2564, 2015.
- [16] Battery Storage for Renewables: market Status and Technology Outlook,” IRENA, January, 2015.
- [17] S Jaffe , “Historical and Forecast Battery Pricing Ranges” – Navigant Research, custom data set, 2014
- [18] B. Kaun and S. Chen, “Cost-Effectiveness of Energy Storage in California: Application of the Energy Storage Valuation Tool to Inform the California Public Utility Commission Proceeding R. 10-12-007,” EPRI, Palo Alto, CA: 2013. 3002001162.
- [19] P. Balducci et al., “Assessment of Energy Storage Alternatives in the Puget Sound Energy System Volume 1: Financial Feasibility Analysis,” PNNL, Richland, WA: 2013. PNNL-23040.
- [20] EvolvDSO, “D1.2: Evaluation of current market architectures and regulatory frameworks and the role of DSOs,” Tech. Rep., 2014.
- [21] EvolvDSO, “D1.3 - Preliminary assessment of the future roles of DSOs, future market architectures and regulatory frameworks for network integration of DRES,” Tech. Rep., 2014.
- [22] K. Knezović, M. Marinelli, P. Codani, and Y. Perez, “Distribution Grid Services and Flexibility Provision by Electric Vehicles: a Review of Options,” Universities Power Engineering Conference (UPEC), 2015 Proceedings of the 50th Intet., pp. 1-6, Staffordshire, 1-4 Sep. 2015.
- [23] G. Girishkumar, B. McCloskey, A. C. Luntz, S. Swanson.